

Tattnall Square Academy

# 2011 GISA State Traditional Tournament

Team Scores

February 4 &amp; 5, 2011

---

1.	Trinity Christian	241.00
2.	Westfield	207.00
2. (tie)	Bulloch	207.00
4.	Mount De Sales	155.00
5.	Mount Vernon Presbyterian	136.00
6.	Windsor	130.50
7.	Southland	116.00
8.	Tiftarea	115.50
9.	Deerfield-Windsor	108.00
10.	Tattnall	105.00
11.	Stratford	64.00
12.	Piedmont	45.00
13.	Mill Springs	40.00
14.	David Emanuel	39.00
15.	Robert Toombs	31.00
15. (tie)	Sherwood	31.00
17.	Unity Christian	27.00
18.	Westwood	26.00
19.	Weber	25.00
20.	Brandon Hall	18.00
20. (tie)	Valwood	18.00
22.	Georgia Christian	3.00

**Tourney Contact**

Jeff Ratliff  
 Tattnall Square Academy  
 111 Trojan Trail  
 Macon GA 31210  
 e-mail: [jratliff@tattnall.org](mailto:jratliff@tattnall.org)

**Publisher**

**Preferred Educational Software**  
 221 Rivers Edge Drive  
 Cherry Valley IL 61010  
 Phone: (888) 959-2016  
 e-mail: [cotterk@pes-sports.com](mailto:cotterk@pes-sports.com)

© 2005 - All rights reserved

Tattnall Square Academy

# 2011 GISA State Traditional Tournament

Place Winners

February 4 & 5, 2011

---

## **Weight: 103**

- 1st: Mitchell Ball, Bulloch 3- 0
- 2nd: Tyler Williams, Tiftarea 2- 1
- 3rd: Mason Purser, Trinity Christian 4- 1
- 4th: Ryan Landreth, Southland 3- 2
- 5th: Jimmy Wood, Brandon Hall 2- 2
- 6th: Hayden Stuart, Deerfield-Windsor 2- 3

## **Weight: 112**

- 1st: Daniel Hendrix, Bulloch 4- 0
- 2nd: Reid Wright, Deerfield-Windsor 2- 1
- 3rd: Bryce Westmoreland, Westfield 3- 1
- 4th: Colt Stephens, Southland 3- 2
- 5th: Brenton Rosa, Trinity Christian 4- 2
- 6th: Patrick Berg, Piedmont 2- 3

## **Weight: 119**

- 1st: Blaze Hyder, Mount De Sales 3- 0
- 2nd: Kyle Gilbert, Windsor 2- 1
- 3rd: Brian Griffin, Tiftarea 3- 1
- 4th: Staten Hicks, Mount Vernon Presbyterian 2- 2
- 5th: John Gowan, Bulloch 3- 2
- 6th: Val Sheridan, Stratford 2- 3

## **Weight: 125**

- 1st: Jon-Luke Cannada, Trinity Christian 3- 0
- 2nd: Chance Isreal, Southland 2- 1
- 3rd: Brock Hyder, Mount De Sales 3- 1
- 4th: Ari Feldstein, Weber 2- 2
- 5th: Harrison Averitt, Bulloch 4- 2
- 6th: Ben Randolph, Stratford 2- 3

## **Weight: 130**

- 1st: Matthew Boles, Trinity Christian 4- 0
- 2nd: Blaine Lovett, Bulloch 2- 1

3rd: Conner Cawthon, Westfield 4- 1  
4th: Chandler Lane, Deerfield-Windsor 2- 2  
5th: Damon Dunwoody, Mount De Sales 3- 2  
6th: John Adams, Tiftarea 1- 3

**Weight: 135**

1st: John Cook, Mount De Sales 3- 0  
2nd: Kyle Wray, Trinity Christian 2- 1  
3rd: Griffin Cawthon, Westfield 3- 1  
4th: Brannon Daniell, Windsor 2- 2  
5th: Jonathan Ward, Tattnall 3- 2  
6th: Eddie Howard, Bulloch 1- 3

**Weight: 140**

1st: Jared Parnell, Westfield 3- 0  
2nd: Ryan Singley, Southland 2- 1  
3rd: Jimmy Martinez, Windsor 3- 1  
4th: Logan Hall, David Emanuel 2- 2  
5th: Matt Fuller, Stratford 2- 2  
6th: Zach Chestnuut, Unity Christian 1- 3

**Weight: 145**

1st: Seth Nicholson, Trinity Christian 4- 0  
2nd: Tyler Johnson, Mill Springs 3- 1  
3rd: Zack Shipp, Windsor 3- 1  
4th: Mac Lanier, Deerfield-Windsor 4- 2  
5th: Colby Collins, Robert Toombs 4- 2  
6th: JB Bahnsen, Valwood 2- 3

**Weight: 152**

1st: Clay Bridges, Westfield 4- 0  
2nd: Andrew Eck, Trinity Christian 2- 1  
3rd: Tripp Gregory, Mount De Sales 5- 1  
4th: Austin Anderson, Tattnall 3- 2  
5th: Robert Barclift, Mount Vernon Presbyterian 3- 2  
6th: Dillian Finch, Bulloch 3- 3

**Weight: 160**

1st: Daniel Hardy, Tiftarea 3- 0  
2nd: Cail Brinson, Tattnall 2- 1  
3rd: Caleb Shipp, Windsor 4- 1  
4th: Rhett Roberts, Piedmont 2- 2  
5th: Austin Newsome, Trinity Christian 2- 2  
6th: Karl Nelson, Westfield 1- 3

**Weight: 171**

1st: Matthew Weigel, Trinity Christian 3- 0  
 2nd: Caleb Bohannon, Bulloch 2- 1  
 3rd: Javaz Williams, Sherwood 4- 1  
 4th: Austin Jenkins, Westfield 3- 2  
 5th: Chris Conforti, Mount De Sales 3- 2  
 6th: Andrew Dobbins, Mount Vernon Presbyterian 2- 3

**Weight: 189**

1st: Codi Johnson, Bulloch 3- 0  
 2nd: Sean Brunson, Mount Vernon Presbyterian 2- 1  
 3rd: Matt Trammell, Deerfield-Windsor 3- 1  
 4th: Miles Seagler, Stratford 2- 2  
 5th: Brandon Jones, Southland 3- 2  
 6th: Clayton Lamar, Westwood 2- 3

**Weight: 215**

1st: Arthur Williams, Tattnall 3- 0  
 2nd: Austin Felts, Tiftarea 2- 1  
 3rd: Blake Layfield, Windsor 4- 1  
 4th: Harrison Stadnik, Deerfield-Windsor 2- 2  
 5th: Daniel Montgomery, Westfield 4- 2  
 6th: George Gavalas, Mount Vernon Presbyterian 2- 3

**Weight: 285**

1st: Alex Head, Mount Vernon Presbyterian 3- 0  
 2nd: Ty Forrester, Westfield 2- 1  
 3rd: Forrest Selman, Tattnall 4- 1  
 4th: Carlton Brooks, Westwood 2- 2  
 5th: Clay Young, Trinity Christian 3- 2  
 6th: Houston Harris, David Emanuel 1- 3

***Tourney Contact***

*Jeff Ratliff*  
*Tattnall Square Academy*  
*111 Trojan Trail*  
*Macon GA 31210*  
 e-mail: [jratliff@tattnall.org](mailto:jratliff@tattnall.org)

***Publisher***

***Preferred Educational Software***  
*221 Rivers Edge Drive*  
*Cherry Valley IL 61010*  
*Phone: (888) 959-2016*  
 e-mail: [cotterk@pes-sports.com](mailto:cotterk@pes-sports.com)

© 2005 - All rights reserved

Tattnall Square Academy

# 2011 GISA State Traditional Tournament

Team Summary

February 4 & 5, 2011

---

## **Brandon Hall 18.00**

(103) Jimmy Wood, Record: 2- 2 5th Place

(152) Carl Williams, Record: 0- 2

## **Bulloch 207.00**

(103) Mitchell Ball, Record: 3- 0 1st Place

(112) Daniel Hendrix, Record: 4- 0 1st Place

(119) John Gowan, Record: 3- 2 5th Place

(125) Harrison Averitt, Record: 4- 2 5th Place

(130) Blaine Lovett, Record: 2- 1 2nd Place

(135) Eddie Howard, Record: 1- 3 6th Place

(140) Will Johnson, Record: 0- 2

(145) Dylan Stuckey, Record: 1- 2

(152) Dillian Finch, Record: 3- 3 6th Place

(160) Asa Johnson, Record: 0- 2

(171) Caleb Bohannon, Record: 2- 1 2nd Place

(189) Codi Johnson, Record: 3- 0 1st Place

(215) Jonathon Lumpkin, Record: 2- 2

(285) Conner Fordham, Record: 1- 2

## **David Emanuel 39.00**

(103) Scott Irvin, Record: 2- 2

(140) Logan Hall, Record: 2- 2 4th Place

(189) Ridge Holland, Record: 2- 2

(285) Houston Harris, Record: 1- 3 6th Place

## **Deerfield-Windsor 108.00**

(103) Hayden Stuart, Record: 2- 3 6th Place

(112) Reid Wright, Record: 2- 1 2nd Place

(130) Chandler Lane, Record: 2- 2 4th Place

(145) Mac Lanier, Record: 4- 2 4th Place

(152) Noah Horton, Record: 2- 2

(189) Matt Trammell, Record: 3- 1 3rd Place

(215) Harrison Stadnik, Record: 2- 2 4th Place

## **Georgia Christian 3.00**

(119) Cole Seashultz, Record: 0- 1

**Mount De Sales 155.00**

(103) Rob Putman, Record: 1- 2

(112) Adam Barth, Record: 1- 2

(119) Blaze Hyder, Record: 3- 0 1st Place

(125) Brock Hyder, Record: 3- 1 3rd Place

(130) Damon Dunwoody, Record: 3- 2 5th Place

(135) John Cook, Record: 3- 0 1st Place

(145) Jack Clark, Record: 0- 2

(152) Tripp Gregory, Record: 5- 1 3rd Place

(160) Caleb Cunard, Record: 1- 2

(171) Chris Conforti, Record: 3- 2 5th Place

(215) Patrick Bradley, Record: 0- 2

**Mill Springs 40.00**

(119) Matthew Sedacca, Record: 0- 0

(145) Tyler Johnson, Record: 3- 1 2nd Place

(160) Doug Seamans, Record: 0- 2

(189) Luke Howell, Record: 1- 2

(285) Brent Shephard, Record: 1- 2

**Mount Vernon Presbyterian 136.00**

(112) Alex Kolb, Record: 0- 2

(119) Staten Hicks, Record: 2- 2 4th Place

(125) Gareth Tremege, Record: 0- 2

(130) William Hays, Record: 1- 2

(135) Avery Fisher, Record: 1- 2

(140) David Eun, Record: 0- 2

(145) Matt Shelden, Record: 1- 2

(152) Robert Barclift, Record: 3- 2 5th Place

(171) Andrew Dobbins, Record: 2- 3 6th Place

(189) Sean Brunson, Record: 2- 1 2nd Place

(215) George Gavalas, Record: 2- 3 6th Place

(285) Alex Head, Record: 3- 0 1st Place

**Piedmont 45.00**

(112) Patrick Berg, Record: 2- 3 6th Place

(125) Mills Smith, Record: 1- 2

(130) Malik Reid, Record: 0- 2

(135) Evan Harvey, Record: 0- 2

(160) Rhett Roberts, Record: 2- 2 4th Place

(189) Payton Cantera, Record: 0- 2

**Robert Toombs 31.00**

- (130) Dillan Coursey, Record: 2- 2
- (145) Colby Collins, Record: 4- 2 5th Place
- (171) Cody Strickland, Record: 1- 2

**Sherwood 31.00**

- (125) Ryan Willis, Record: 0- 2
- (145) Brian Baggett, Record: 1- 2
- (171) Javaz Williams, Record: 4- 1 3rd Place
- (285) D` Andre Taylor, Record: 0- 2

**Southland 116.00**

- (103) Ryan Landreth, Record: 3- 2 4th Place
- (112) Colt Stephens, Record: 3- 2 4th Place
- (125) Chance Isreal, Record: 2- 1 2nd Place
- (130) Gary Ingram, Record: 0- 2
- (135) Mitch Eason, Record: 0- 2
- (140) Ryan Singley, Record: 2- 1 2nd Place
- (152) Cauldin Smith, Record: 0- 2
- (171) Lawton Williams, Record: 2- 2
- (189) Brandon Jones, Record: 3- 2 5th Place
- (215) Andrew Alexander, Record: 1- 2
- (285) Cody Jones, Record: 0- 2

**Stratford 64.00**

- (112) Griffin Hutchins, Record: 0- 2
- (119) Val Sheridan, Record: 2- 3 6th Place
- (125) Ben Randolph, Record: 2- 3 6th Place
- (140) Matt Fuller, Record: 2- 2 5th Place
- (145) Patrick Schroder, Record: 1- 2
- (152) Holden Parker, Record: 0- 2
- (171) Austin Oren, Record: 1- 2
- (189) Miles Seagler, Record: 2- 2 4th Place

**Trinity Christian 241.00**

- (103) Mason Purser, Record: 4- 1 3rd Place
- (112) Brenton Rosa, Record: 4- 2 5th Place
- (119) EJ Barr, Record: 1- 2
- (125) Jon-Luke Cannada, Record: 3- 0 1st Place
- (130) Matthew Boles, Record: 4- 0 1st Place
- (135) Kyle Wray, Record: 2- 1 2nd Place
- (145) Seth Nicholson, Record: 4- 0 1st Place
- (152) Andrew Eck, Record: 2- 1 2nd Place
- (160) Austin Newsome, Record: 2- 2 5th Place
- (171) Matthew Weigel, Record: 3- 0 1st Place
- (215) Mike Wheelless, Record: 1- 2
- (285) Clay Young, Record: 3- 2 5th Place

**Tiftarea 115.50**

- (103) Tyler Williams, Record: 2- 1 2nd Place
- (119) Brian Griffin, Record: 3- 1 3rd Place
- (125) Joseph Spinks, Record: 1- 2
- (130) John Adams, Record: 1- 3 6th Place
- (145) Henry Cox, Record: 1- 2
- (160) Daniel Hardy, Record: 3- 0 1st Place
- (215) Austin Felts, Record: 2- 1 2nd Place

**Tattnall 105.00**

- (135) Jonathan Ward, Record: 3- 2 5th Place
- (145) Austin Jones, Record: 0- 2
- (152) Austin Anderson, Record: 3- 2 4th Place
- (160) Cail Brinson, Record: 2- 1 2nd Place
- (171) Wyatt Stovall, Record: 0- 2
- (189) Jack Lee, Record: 0- 2
- (215) Arthur Williams, Record: 3- 0 1st Place
- (285) Forrest Selman, Record: 4- 1 3rd Place

**Unity Christian 27.00**

- (103) Noah Beilstein, Record: 0- 2
- (112) JP Popham, Record: 2- 2
- (140) Zach Chestnuut, Record: 1- 3 6th Place
- (152) Richard Cooper, Record: 0- 2
- (215) Noah Hammel, Record: 0- 2

**Valwood 18.00**

- (119) Tyler Phillips, Record: 1- 2
- (145) JB Bahnsen, Record: 2- 3 6th Place
- (171) Griffin Allen, Record: 0- 2

**Weber 25.00**

- (103) Jonathan Geller, Record: 0- 2
- (112) Andrew Shutzberg, Record: 0- 2
- (125) Ari Feldstein, Record: 2- 2 4th Place
- (130) Jacob Seagraves, Record: 1- 2
- (145) Kenton Gross, Record: 0- 2
- (152) Dylan Shaban, Record: 0- 2

**Westfield 207.00**

- (103) Dayton Hammerle, Record: 0- 2
- (112) Bryce Westmoreland, Record: 3- 1 3rd Place
- (125) Ben Brooks, Record: 1- 2
- (130) Conner Cawthon, Record: 4- 1 3rd Place
- (135) Griffin Cawthon, Record: 3- 1 3rd Place



- (140) Jared Parnell, Record: 3- 0 1st Place
- (145) Cotton Hammerle, Record: 2- 2
- (152) Clay Bridges, Record: 4- 0 1st Place
- (160) Karl Nelson, Record: 1- 3 6th Place
- (171) Austin Jenkins, Record: 3- 2 4th Place
- (189) Drew Forrester, Record: 1- 2
- (215) Daniel Montgomery, Record: 4- 2 5th Place
- (285) Ty Forrester, Record: 2- 1 2nd Place

**Windsor 130.50**

- (112) Joseph Huckabe, Record: 0- 2
- (119) Kyle Gilbert, Record: 2- 1 2nd Place
- (130) Greg Thomas, Record: 1- 2
- (135) Brannon Daniell, Record: 2- 2 4th Place
- (140) Jimmy Martinez, Record: 3- 1 3rd Place
- (145) Zack Shipp, Record: 3- 1 3rd Place
- (152) Delenn Farmer, Record: 1- 2
- (160) Caleb Shipp, Record: 4- 1 3rd Place
- (171) James Perkins, Record: 0- 2
- (215) Blake Layfield, Record: 4- 1 3rd Place

**Westwood 26.00**

- (189) Clayton Lamar, Record: 2- 3 6th Place
- (215) Ryan Coker, Record: 0- 2
- (285) Carlton Brooks, Record: 2- 2 4th Place

***Tourney Contact***

*Jeff Ratliff*  
*Tattnall Square Academy*  
*111 Trojan Trail*  
*Macon GA 31210*  
e-mail: [jratliff@tattnall.org](mailto:jratliff@tattnall.org)

***Publisher***

***Preferred Educational Software***  
*221 Rivers Edge Drive*  
*Cherry Valley IL 61010*  
*Phone: (888) 959-2016*  
e-mail: [cotterk@pes-sports.com](mailto:cotterk@pes-sports.com)

© 2005 - All rights reserved

2011 GISA State Traditional Tournament  
Tattnall Square Academy  
February 4 & 5, 2011

Weight: 103

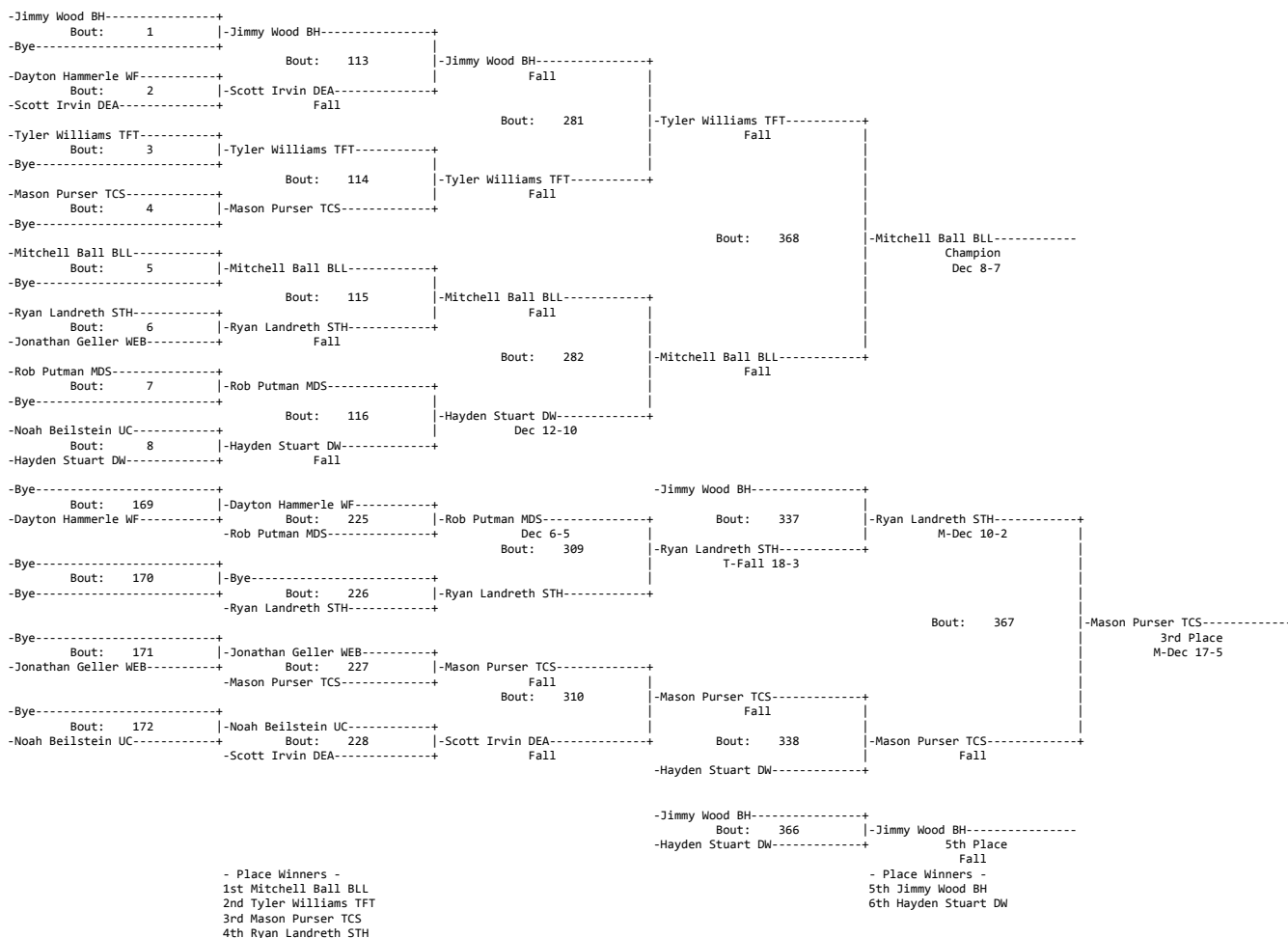

Weight: 112

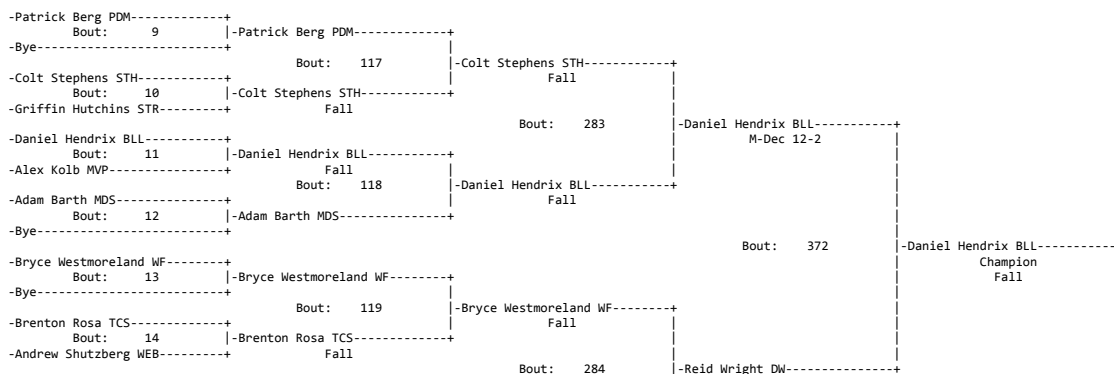

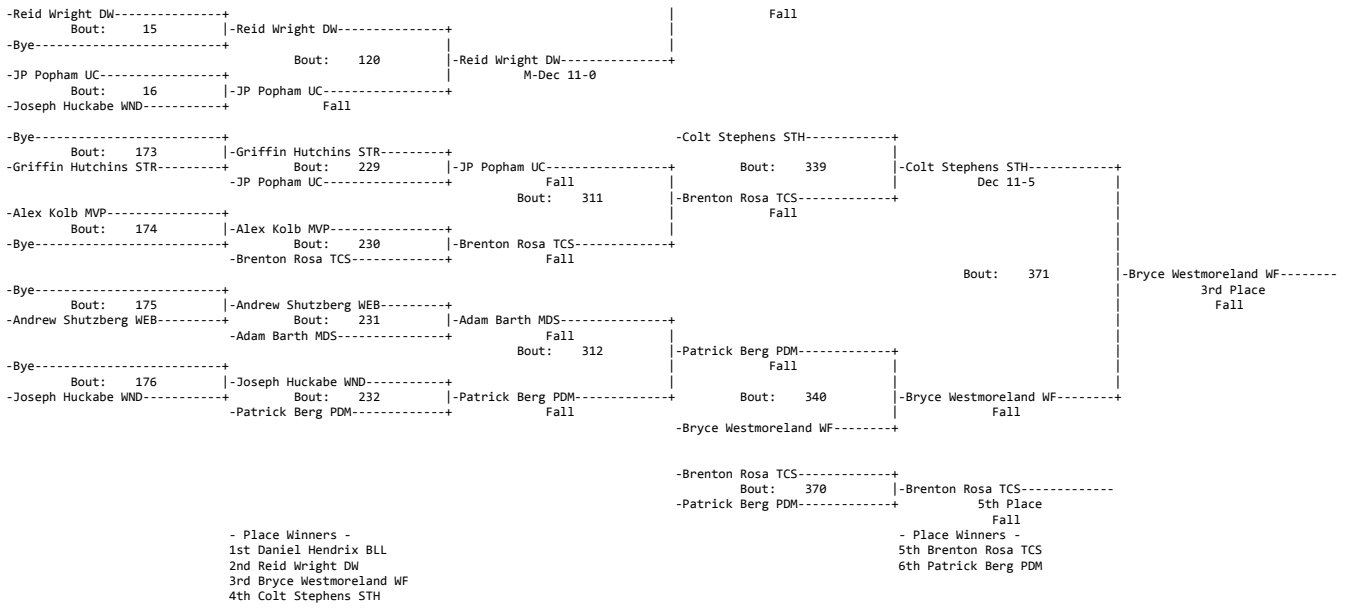

**Weight: 119**

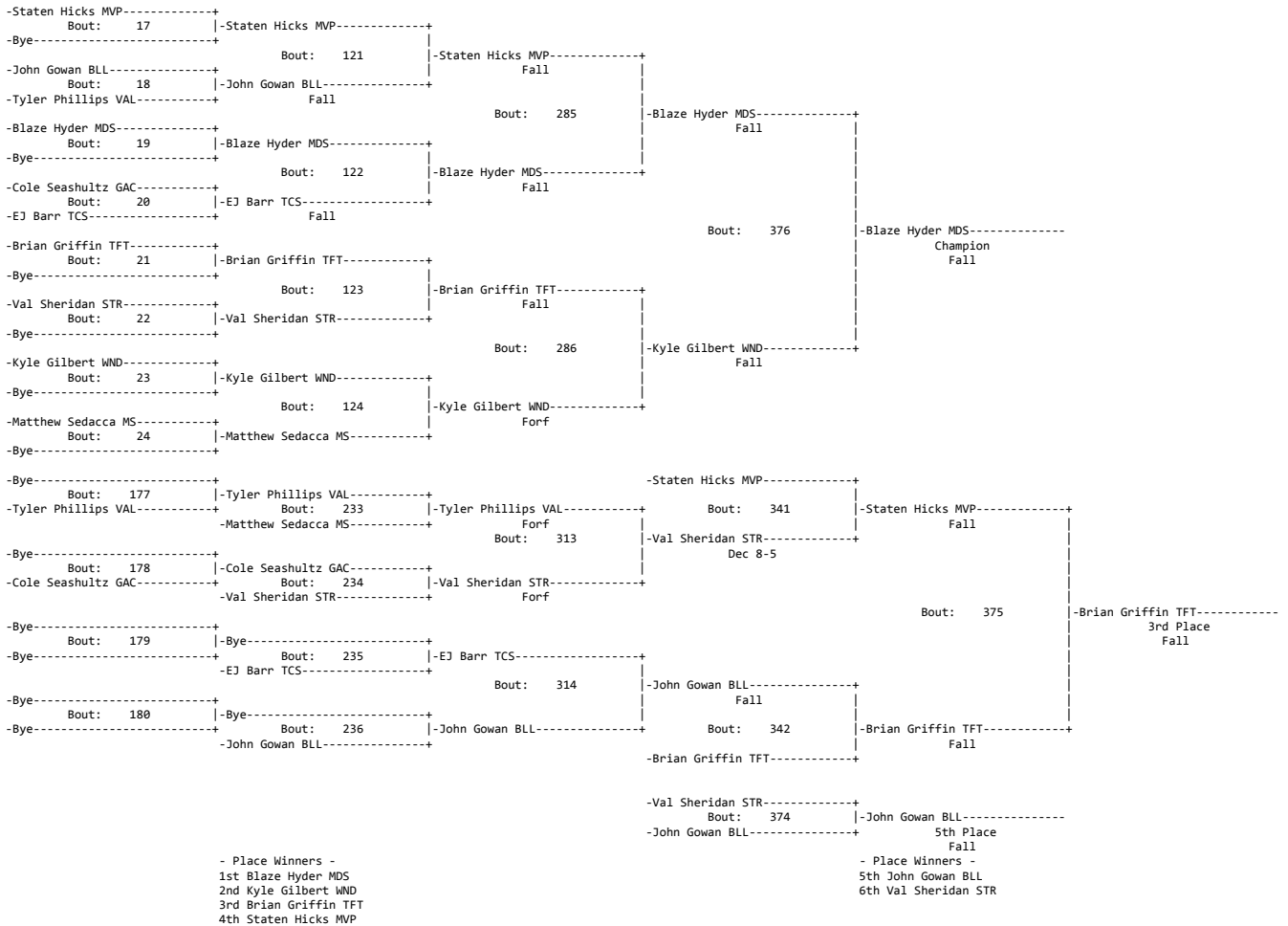



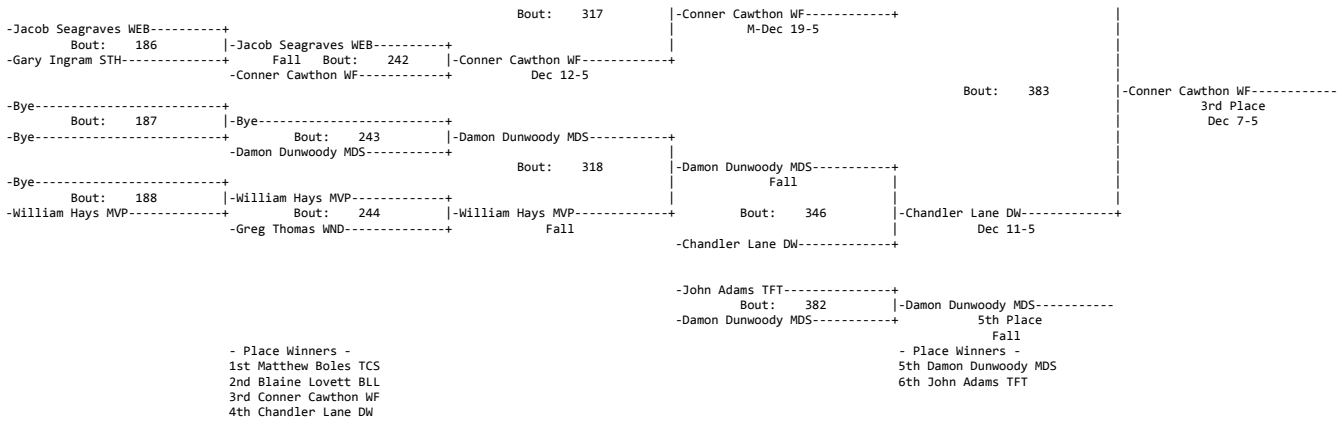

**Weight: 135**

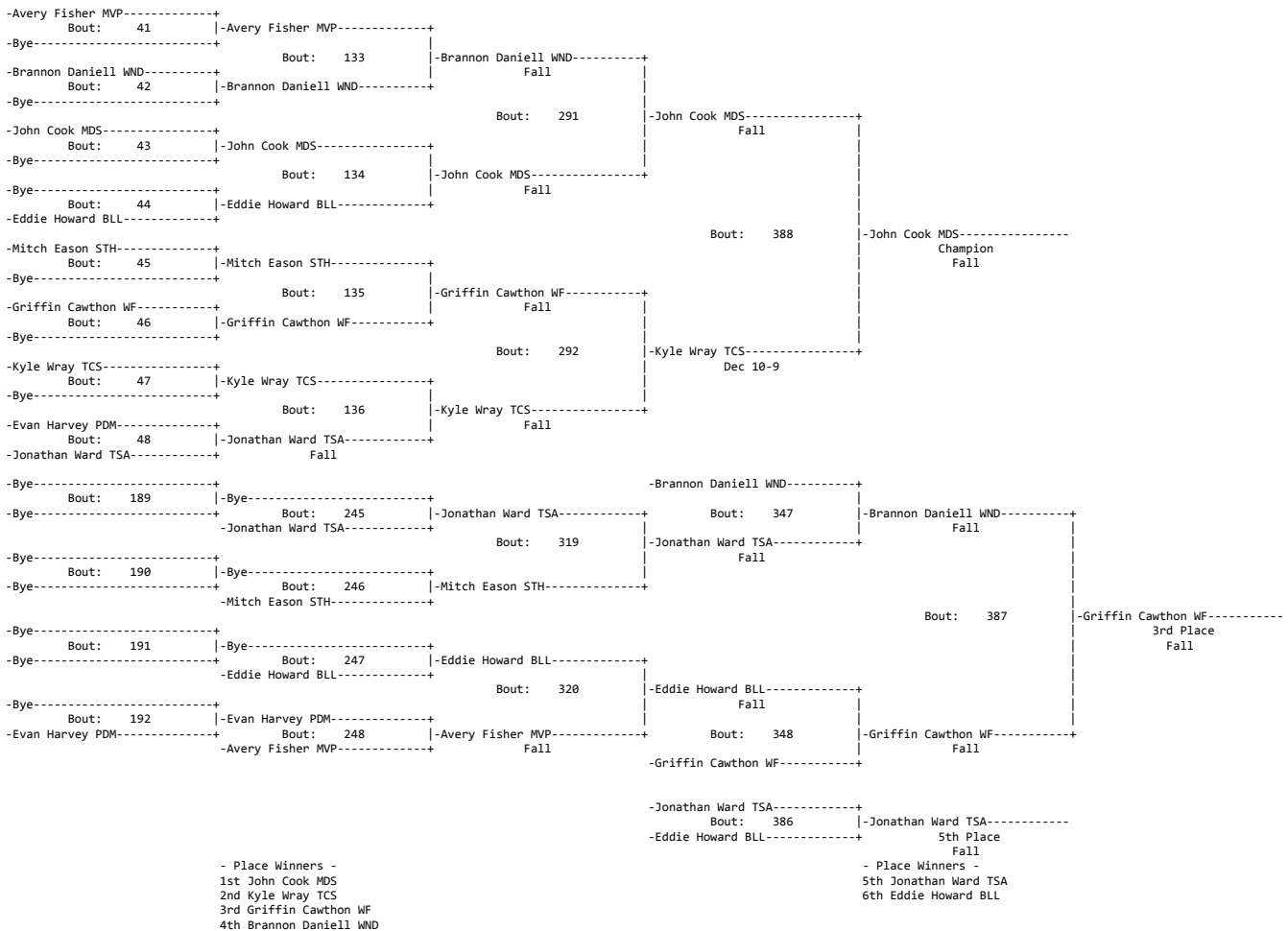

**Weight: 140**

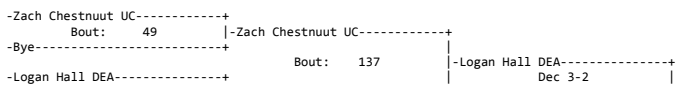

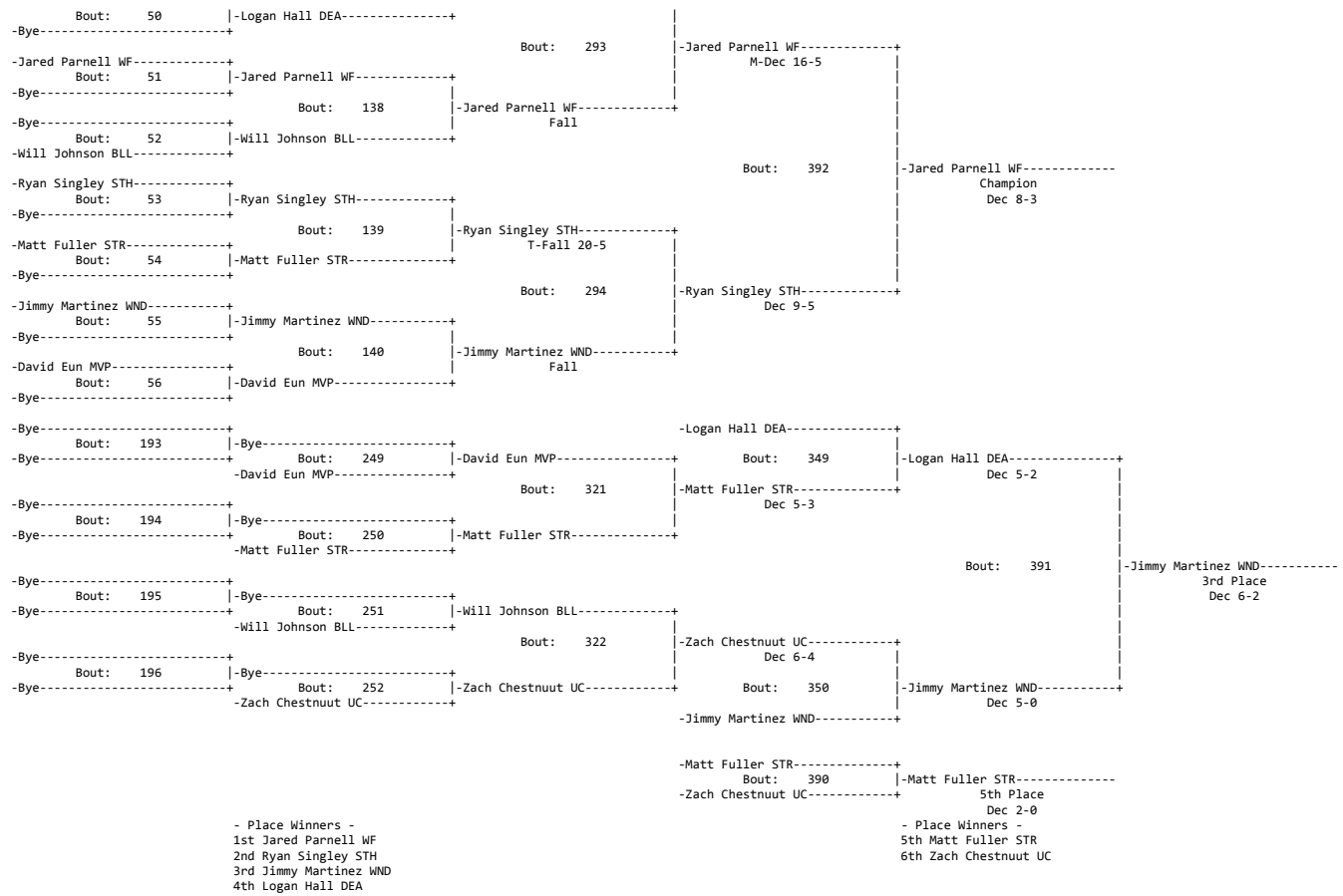

**Weight: 145**

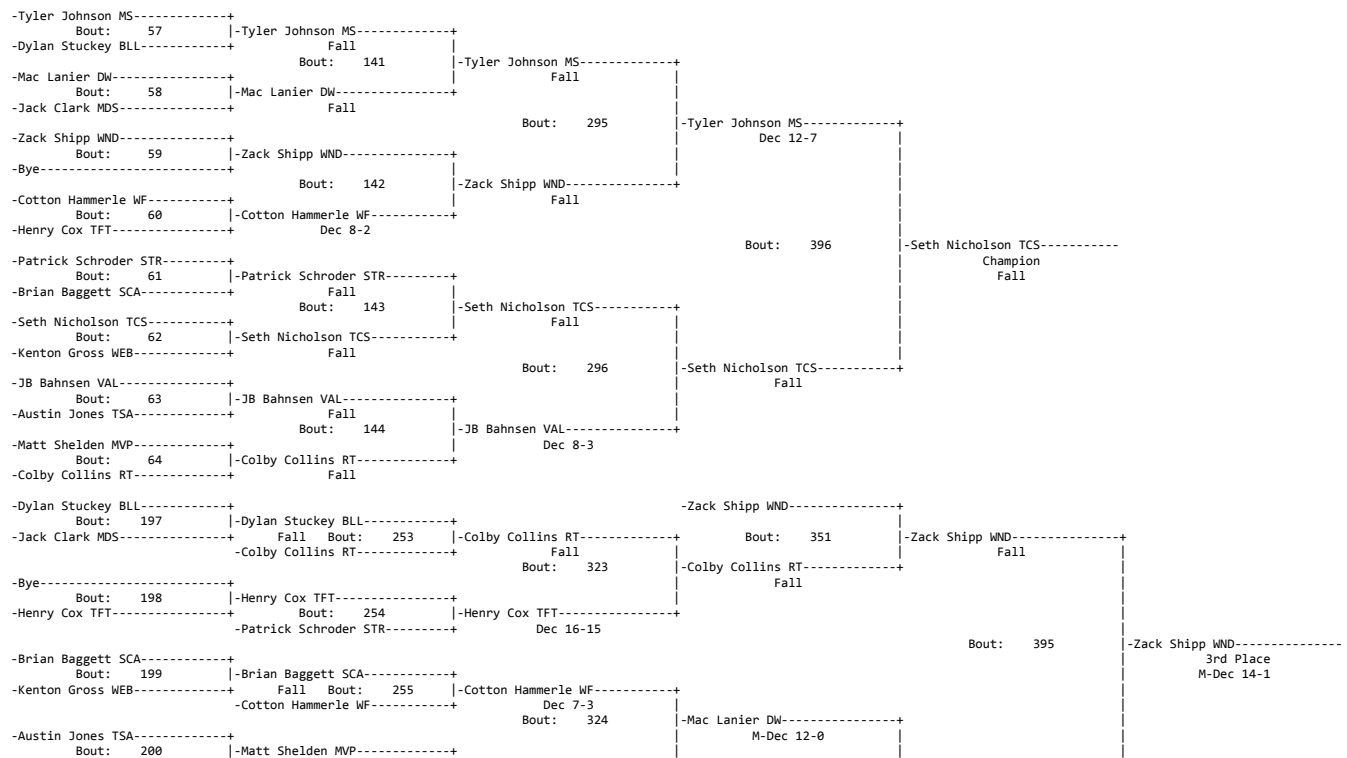

```

-Matt Shelden MVP-----+      Fall Bout: 256  |-Mac Lanier DW-----+      Bout: 352      |-Mac Lanier DW-----+
-Mac Lanier DW-----+      Fall                      -JB Bahnsen VAL-----+
                                         -Colby Collins RT-----+
                                         Bout: 394      |-Colby Collins RT-----+
                                         -JB Bahnsen VAL-----+      5th Place
                                          Fall
- Place Winners -
1st Seth Nicholson TCS
2nd Tyler Johnson MS
3rd Zack Shipp WND
4th Mac Lanier DW
                                     - Place Winners -
                                     5th Colby Collins RT
                                     6th JB Bahnsen VAL
    
```

**Weight: 152**

```

-Robert Barclift MVP-----+
  Bout: 65  |-Robert Barclift MVP-----+
-Holden Parker STR-----+      Fall
      Bout: 145  |-Robert Barclift MVP-----+
-DeLenn Farmer WND-----+      Dec 7-0
  Bout: 66  |-DeLenn Farmer WND-----+
-Bye-----+
                                     Bout: 297  |-Clay Bridges WF-----+
-Clay Bridges WF-----+      Fall
      Bout: 67  |-Clay Bridges WF-----+
-Dylan Shaban WEB-----+      Fall
      Bout: 146  |-Clay Bridges WF-----+
-Clay Bridges WF-----+      Fall
-Clay Bridges WF-----+
  Bout: 68  |-Dillian Finch BLL-----+
-Dillian Finch BLL-----+      Fall
                                     Bout: 400  |-Clay Bridges WF-----+
-Clay Bridges WF-----+      Champion
      Bout: 69  |-Cauldin Smith STH-----+      Dec 6-2
-Bye-----+
                                     Bout: 147  |-Austin Anderson TSA-----+
-Austin Anderson TSA-----+      Dec 11-4
      Bout: 70  |-Austin Anderson TSA-----+
-Carl Williams BH-----+      Fall
                                     Bout: 298  |-Andrew Eck TCS-----+
-Andrew Eck TCS-----+      Dec 5-2
      Bout: 71  |-Andrew Eck TCS-----+
-Bye-----+
                                     Bout: 148  |-Andrew Eck TCS-----+
-Richard Cooper UC-----+      M-Dec 8-0
      Bout: 72  |-Tripp Gregory MDS-----+
-Tripp Gregory MDS-----+      Fall
                                     -Robert Barclift MVP-----+
-Holden Parker STR-----+      Bout: 201  |-Holden Parker STR-----+
      Bout: 201  |-Holden Parker STR-----+      Bout: 257  |-Tripp Gregory MDS-----+
-Bye-----+      Fall
      Bout: 257  |-Tripp Gregory MDS-----+      Bout: 353  |-Tripp Gregory MDS-----+
-Tripp Gregory MDS-----+      Dec 6-2
      Bout: 325  |-Tripp Gregory MDS-----+
-Dylan Shaban WEB-----+      Fall
      Bout: 202  |-Noah Horton DW-----+      Bout: 326  |-Dillian Finch BLL-----+
-Bye-----+      Fall
      Bout: 203  |-Carl Williams BH-----+      Bout: 326  |-Dillian Finch BLL-----+
-Carl Williams BH-----+      Fall
      Bout: 259  |-Dillian Finch BLL-----+
      Bout: 204  |-Richard Cooper UC-----+      Bout: 354  |-Austin Anderson TSA-----+
-Richard Cooper UC-----+      M-Dec 14-4
      Bout: 260  |-DeLenn Farmer WND-----+
-DeLenn Farmer WND-----+      M-Dec 14-4
                                     -Robert Barclift MVP-----+
                                     Bout: 398  |-Robert Barclift MVP-----+
-Dillian Finch BLL-----+      5th Place
                                     Fall
- Place Winners -
1st Clay Bridges WF
2nd Andrew Eck TCS
3rd Tripp Gregory MDS
4th Austin Anderson TSA
                                     - Place Winners -
                                     5th Robert Barclift MVP
                                     6th Dillian Finch BLL
    
```

**Weight: 160**

```

-Rhett Roberts PDM-----+
  Bout: 73  |-Rhett Roberts PDM-----+
-Bye-----+
      Bout: 149  |-Caleb Shipp WND-----+
-Karl Nelson WF-----+      Dec 8-7
      Bout: 74  |-Caleb Shipp WND-----+
-Caleb Shipp WND-----+      Dec 8-2
                                     Bout: 299  |-Daniel Hardy TFT-----+
-Daniel Hardy TFT-----+      Fall
      Bout: 75  |-Daniel Hardy TFT-----+
-Bye-----+
                                     Bout: 150  |-Daniel Hardy TFT-----+
-Asa Johnson BLL-----+      M-Dec 12-4
      Bout: 76  |-Asa Johnson BLL-----+
-Bye-----+
                                     Bout: 404  |-Daniel Hardy TFT-----+
-Austin Newsome TCS-----+      Champion
      Bout: 77  |-Austin Newsome TCS-----+      Fall
    
```

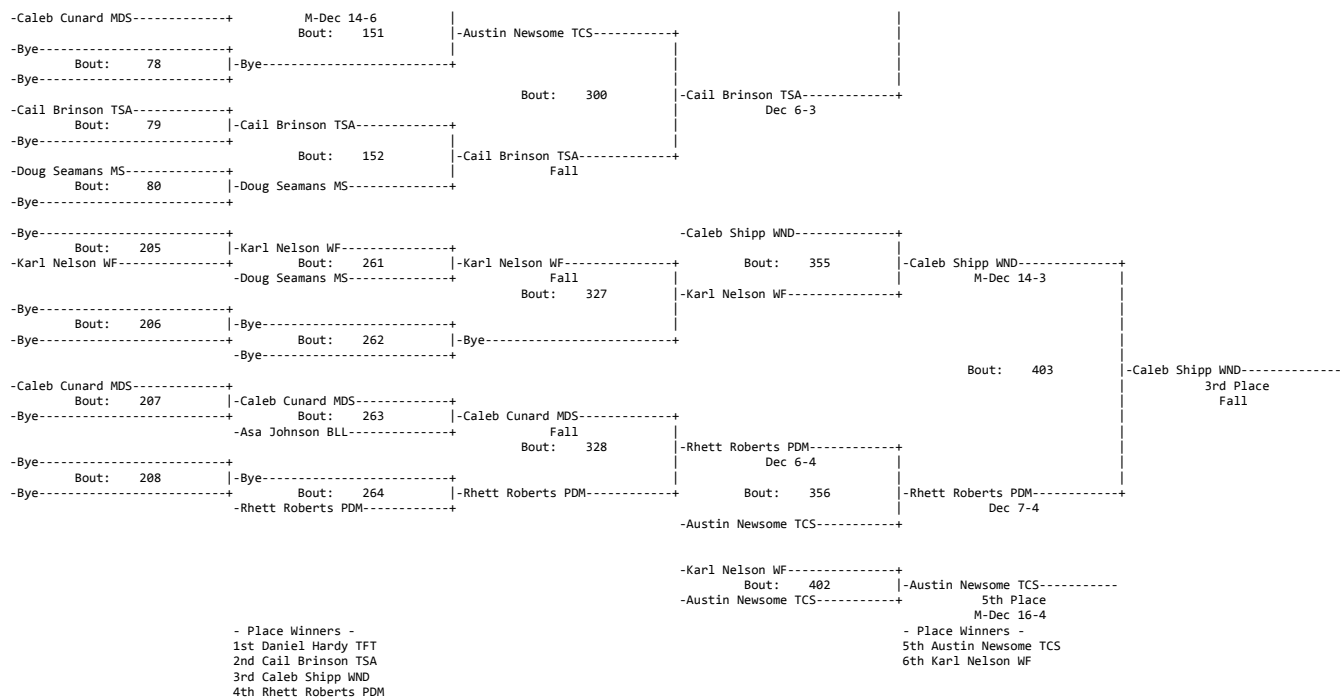

Weight: 171

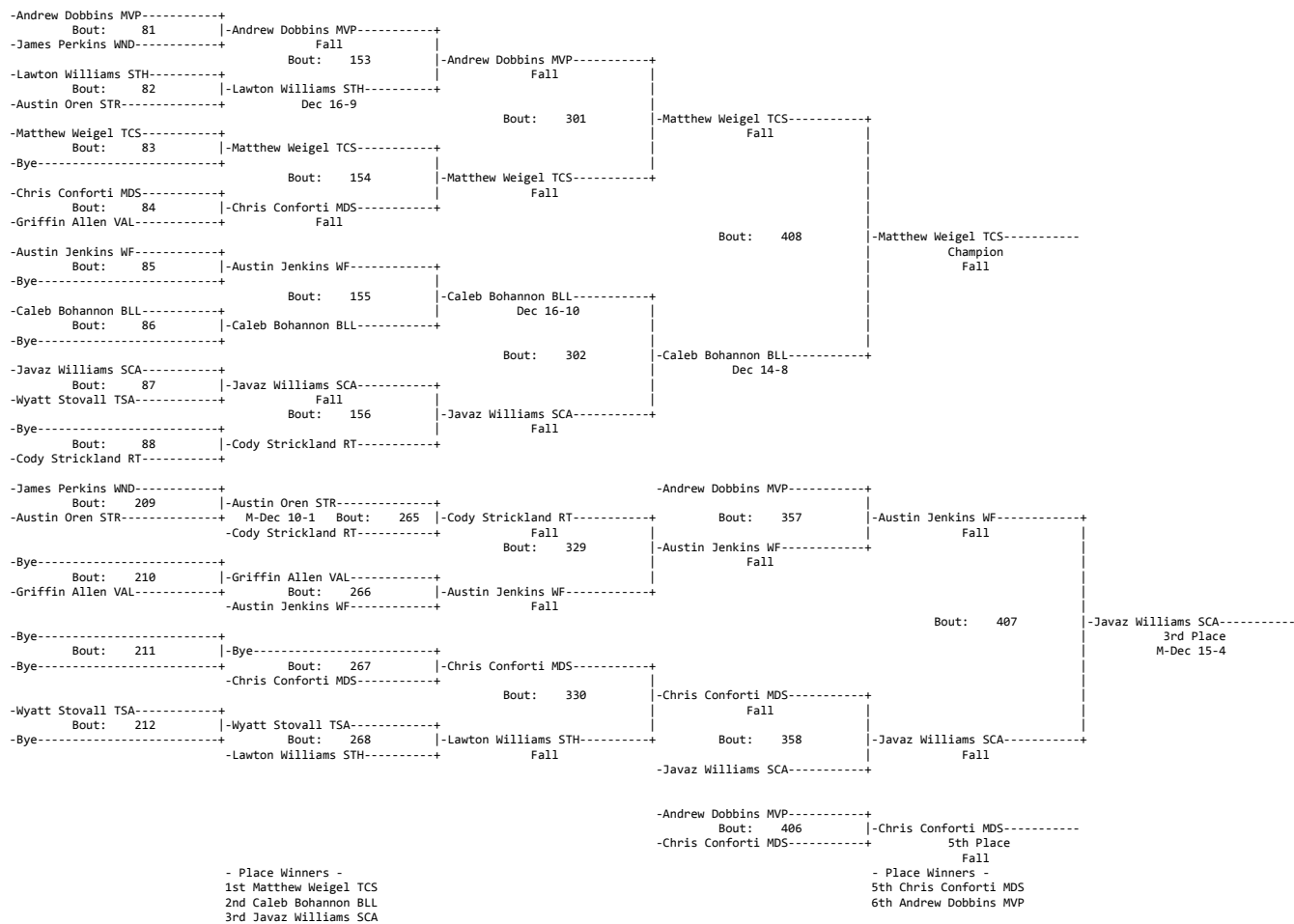



4th Austin Jenkins WF

**Weight: 189**

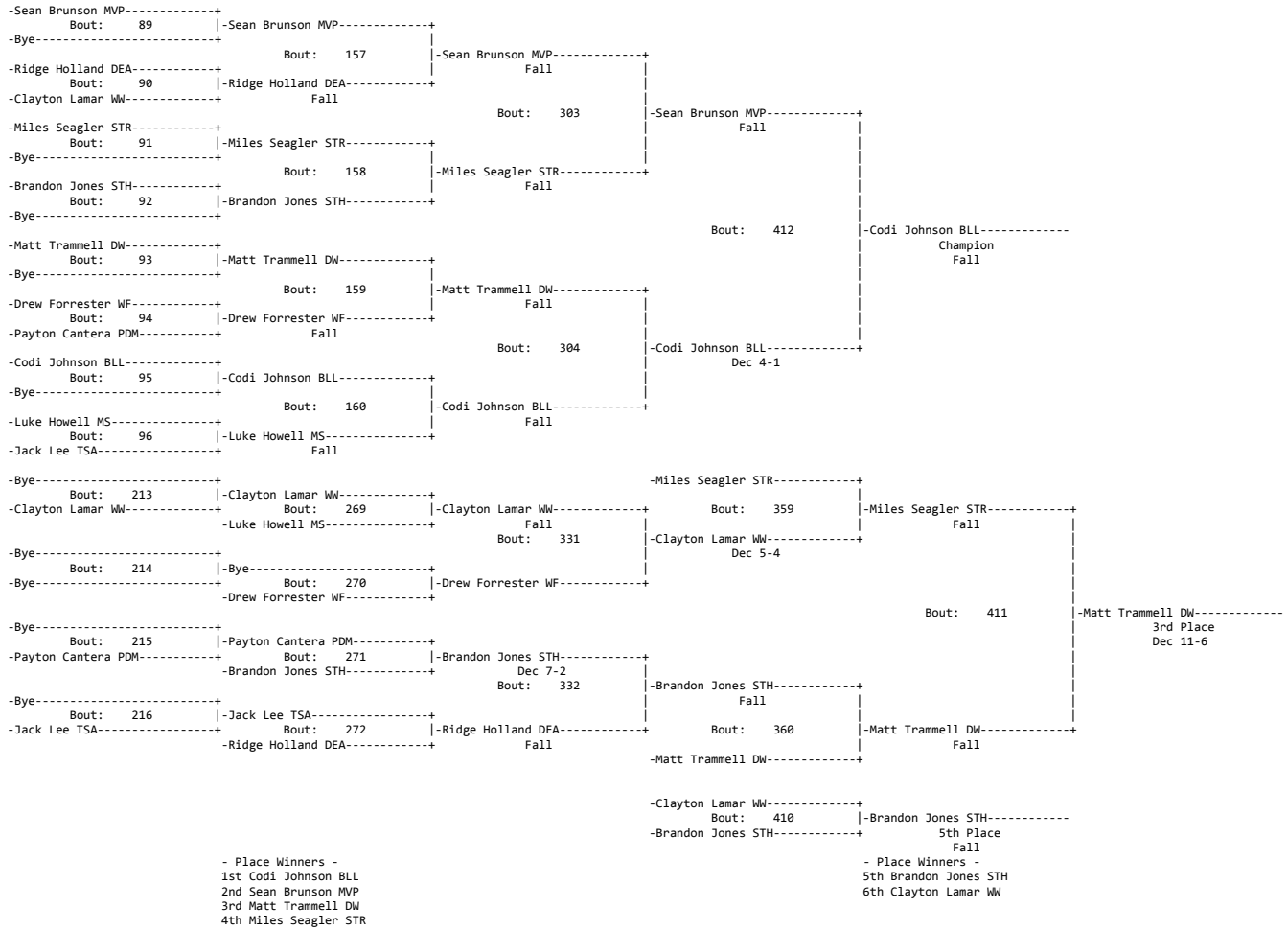

**Weight: 215**

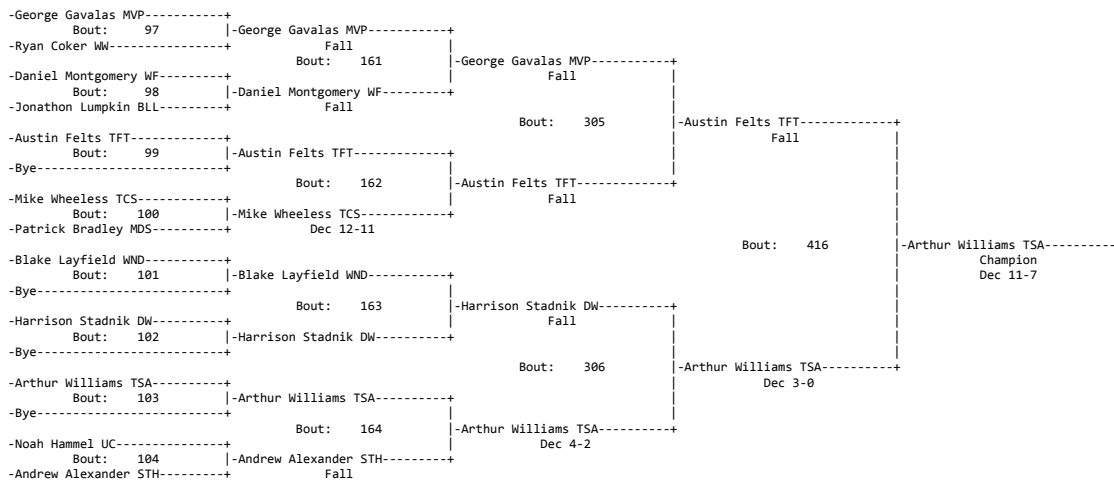

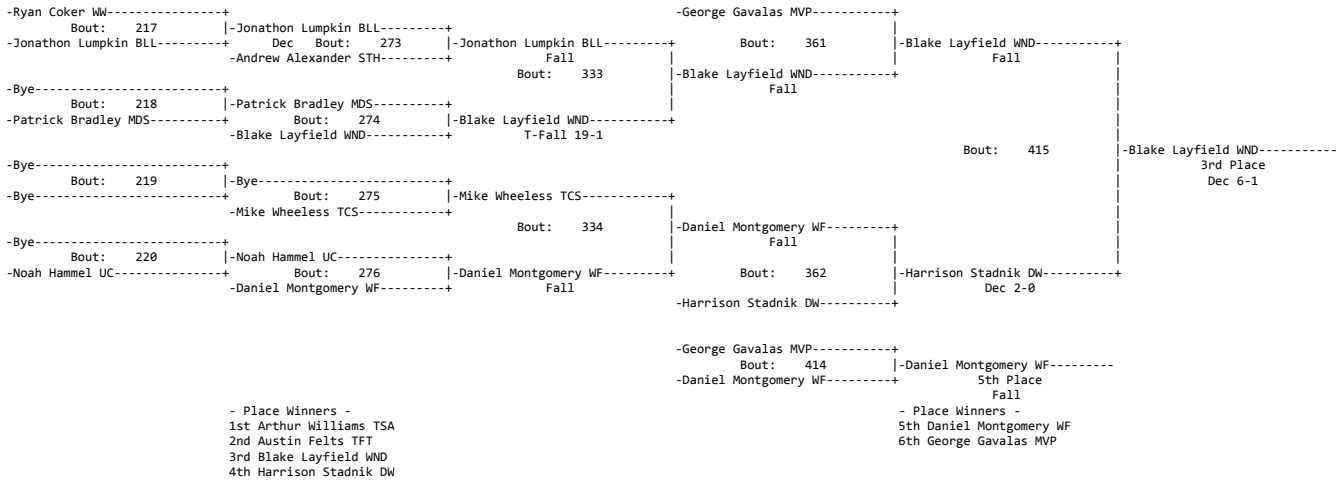

**Weight: 285**

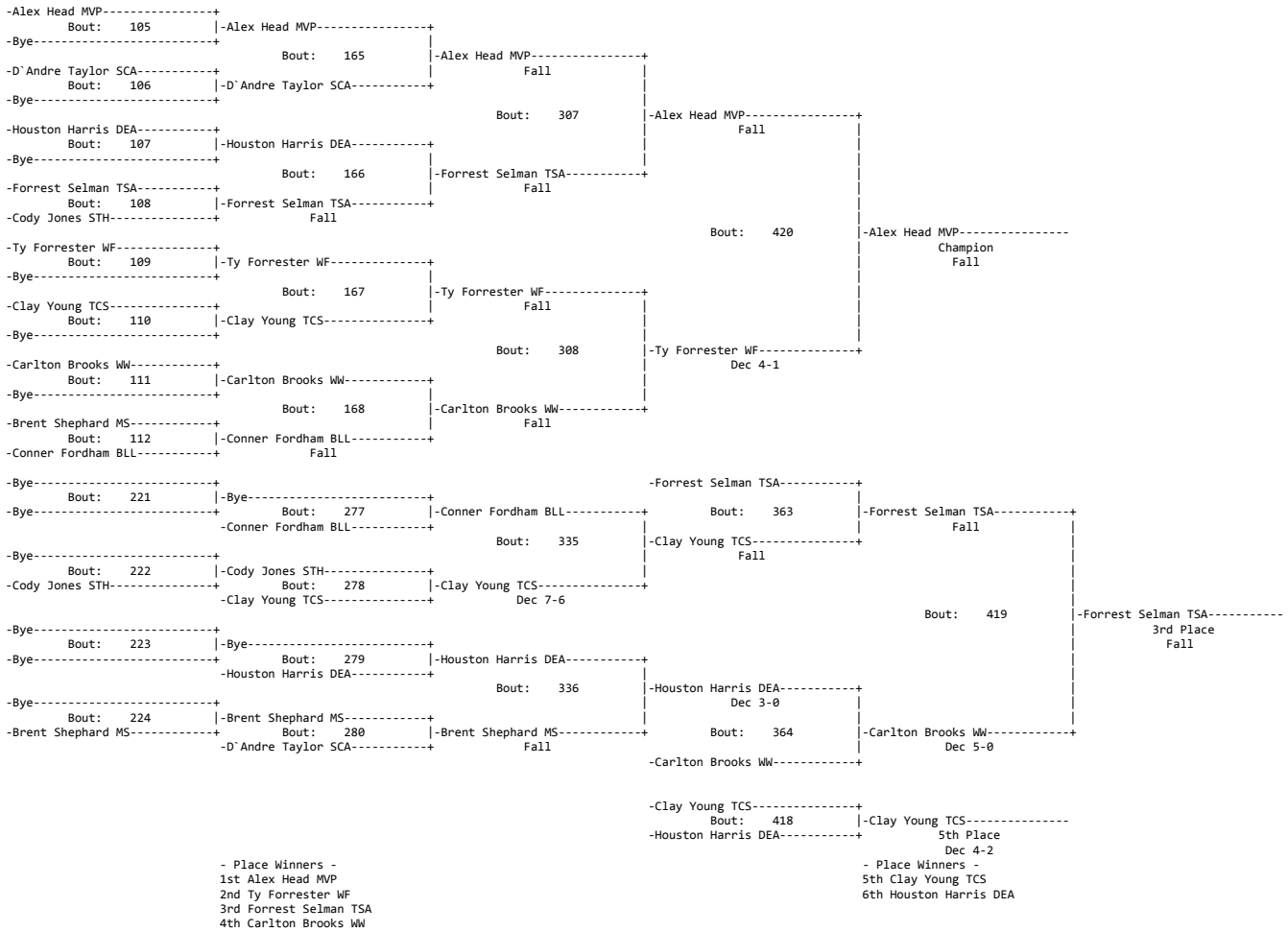

[Preferred Educational Software](http://www.pes-sports.com)  
 9585 Woodgate Lane  
 Byron IL 61010  
 Phone: (888) 959-2016  
 e-mail: [cotterk@pes-sports.com](mailto:cotterk@pes-sports.com)